

CL = CENTER LINE
 R/W = RIGHT OF WAY
 GB = GRADE BREAK
 MIN = MINIMUM

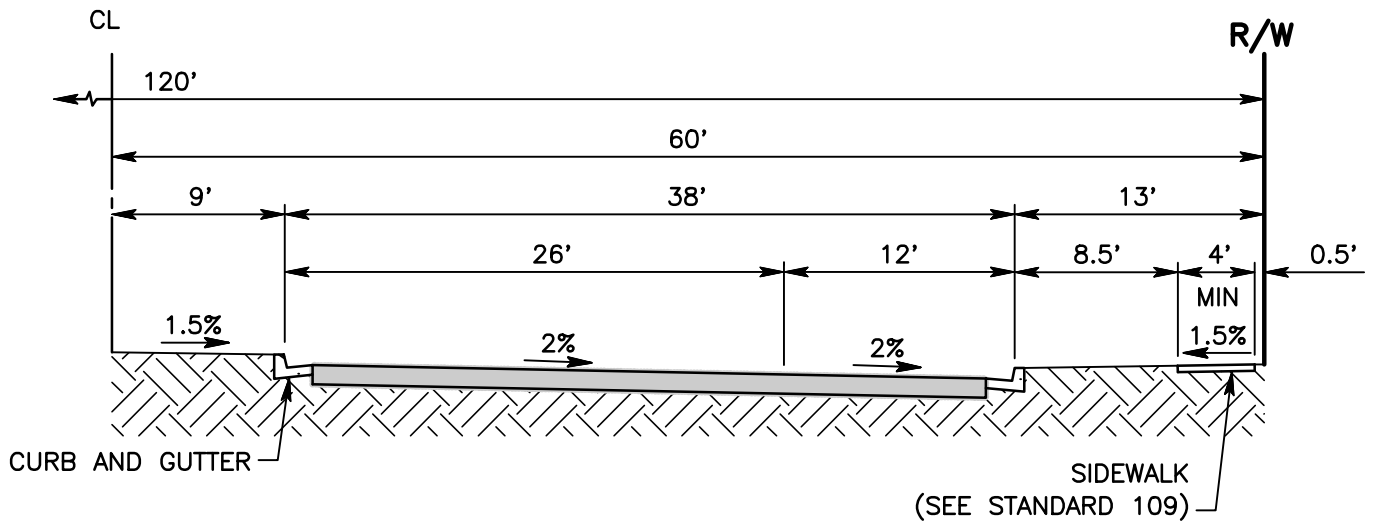

**TYPICAL HALF SECTION
 WITH STRAIGHT GRADE**

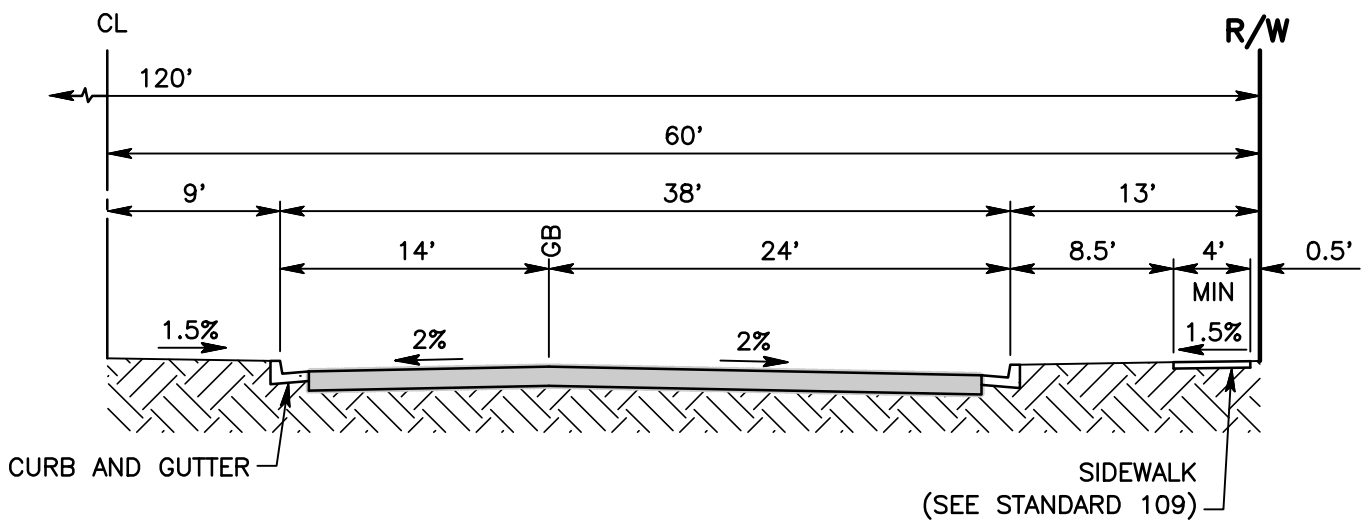

**TYPICAL HALF SECTION
 WITH GRADE BREAK**

NOTES:

1. STRUCTURAL SECTION OF ROADWAY SHALL BE DETERMINED FROM SOIL TESTS AND SO INDICATED ON THE CONSTRUCTION PLANS.
2. CONSTRUCTION OUTSIDE OF RIGHT OF WAY LINE SHALL REQUIRE SLOPE EASEMENTS.



SAN BERNARDINO COUNTY DEPARTMENT OF PUBLIC WORKS

MAJOR DIVIDED HIGHWAY

BRENDON P. BIGGS, PE
 DIRECTOR OF PUBLIC
 WORKS/ROAD
 COMMISSIONER

100