

CL = CENTER LINE  
 R/W = RIGHT OF WAY  
 ADT = AVERAGE DAILY TRAFFIC

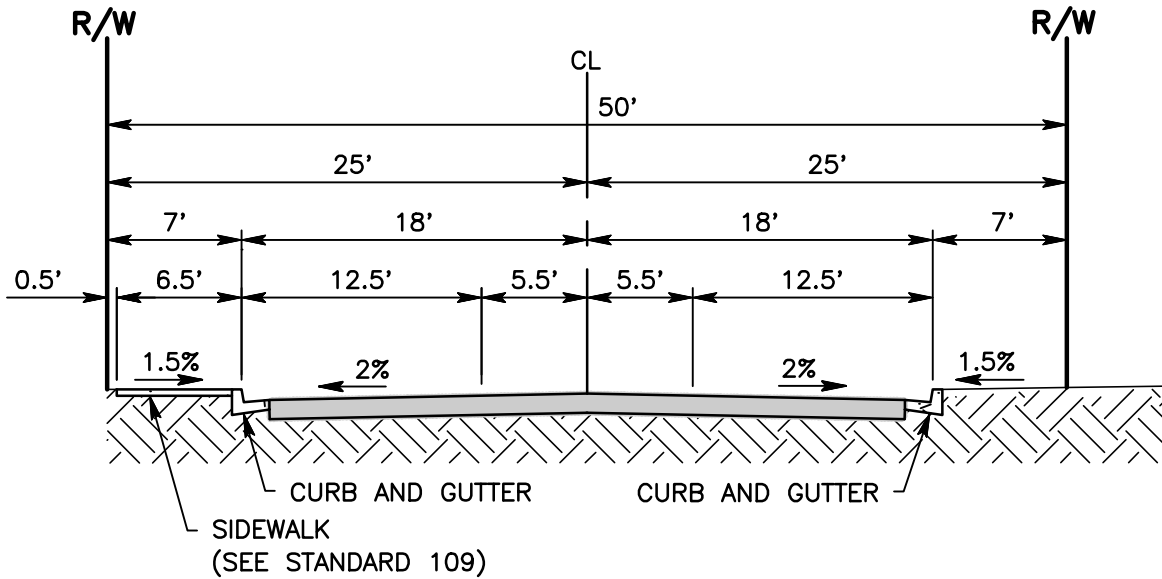

**TYPICAL SECTION**

**NOTES:**

1. THIS TYPICAL SECTION SHALL BE USED ONLY ON LOCAL STREETS SUCH AS CUL-DE-SACS, LOOPS AND STREETS THAT DO NOT CARRY THROUGH TYPE TRAFFIC. THE USE SHALL BE LIMITED TO STREETS WHICH ARE PROJECTED TO CARRY LESS THAN 1,000 ADT UPON ULTIMATE DEVELOPMENT OF THE AREA.
2. STRUCTURAL SECTION OF ROADWAY SHALL BE DETERMINED FROM SOIL TESTS AND SO INDICATED ON CONSTRUCTION PLANS.
3. CONSTRUCTION OUTSIDE RIGHT OF WAY WILL REQUIRE SLOPE EASEMENTS.
4. TILT SECTION SHALL CONFORM TO STANDARD 104.



**SAN BERNARDINO COUNTY DEPARTMENT OF PUBLIC WORKS**

**LOCAL STREET  
 (LESS THAN 1,000 ADT)**

BRENDON P. BIGGS, PE  
 DIRECTOR OF PUBLIC  
 WORKS/ROAD  
 COMMISSIONER

**104A**