

CL = CENTER LINE
 R/W = RIGHT OF WAY
 MAX = MAXIMUM
 GB = GRADE BREAK

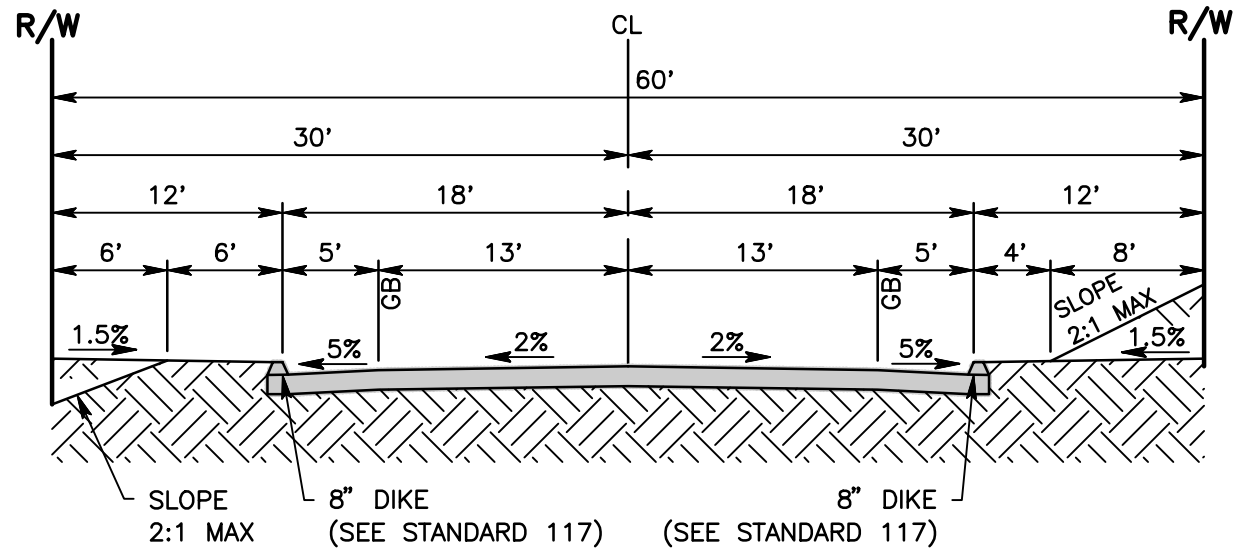

TYPICAL SECTION
 WHERE REQUIRED FOR DRAINAGE PURPOSES

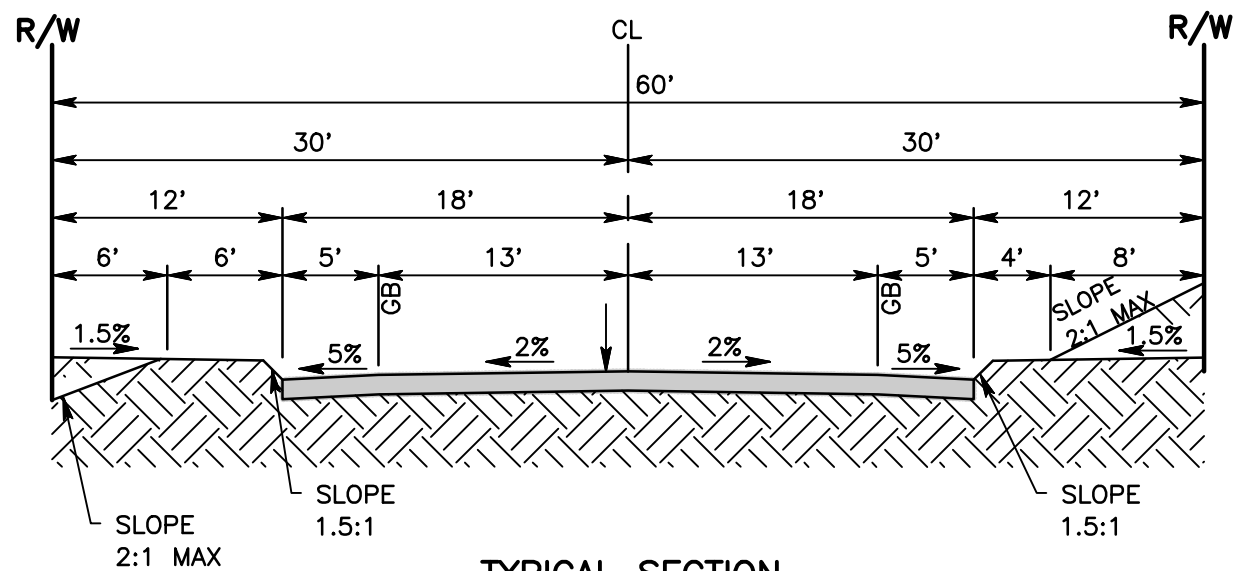

TYPICAL SECTION

NOTES:

1. STRUCTURAL SECTION OF ROADWAY SHALL BE DETERMINED FROM SOILS TESTS AND SO INDICATED ON CONSTRUCTION PLANS.
2. CONSTRUCTION OUTSIDE RIGHT OF WAY LINE SHALL REQUIRE SLOPE EASEMENTS.
3. SLOPE REQUIREMENT MAY BE VARIED BY SUBMISSION OF SOILS REPORT.



SAN BERNARDINO COUNTY DEPARTMENT OF PUBLIC WORKS

PAVED ROAD

BRENDON P. BIGGS, PE
 DIRECTOR OF PUBLIC
 WORKS/ROAD
 COMMISSIONER

114A