

CROWN CURVE DATA				
POINT	RADIUS	DELTA	LENGTH	TANGENT
A	169.50'	32°47'06"	96.99'	49.86'

CL = CENTER LINE
R/W = RIGHT OF WAY

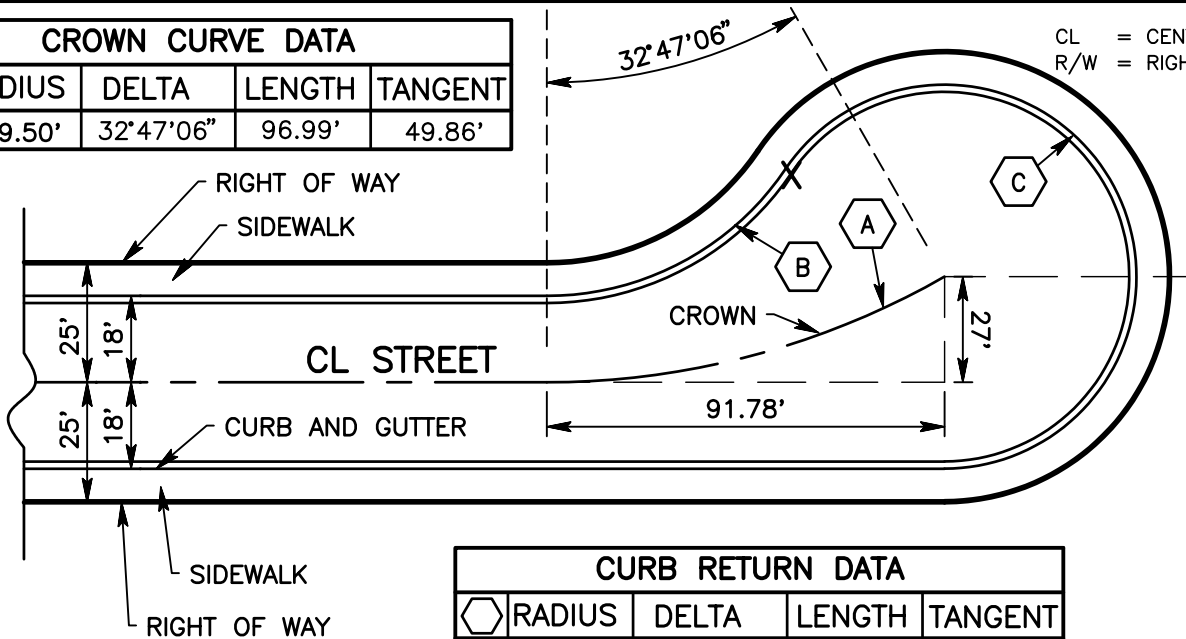

PLAN

CURB RETURN DATA				
POINT	RADIUS	DELTA	LENGTH	TANGENT
B	60.00'	60°56'27"	63.82'	35.30'
C	45.00'	165°28'13"	129.96'	----

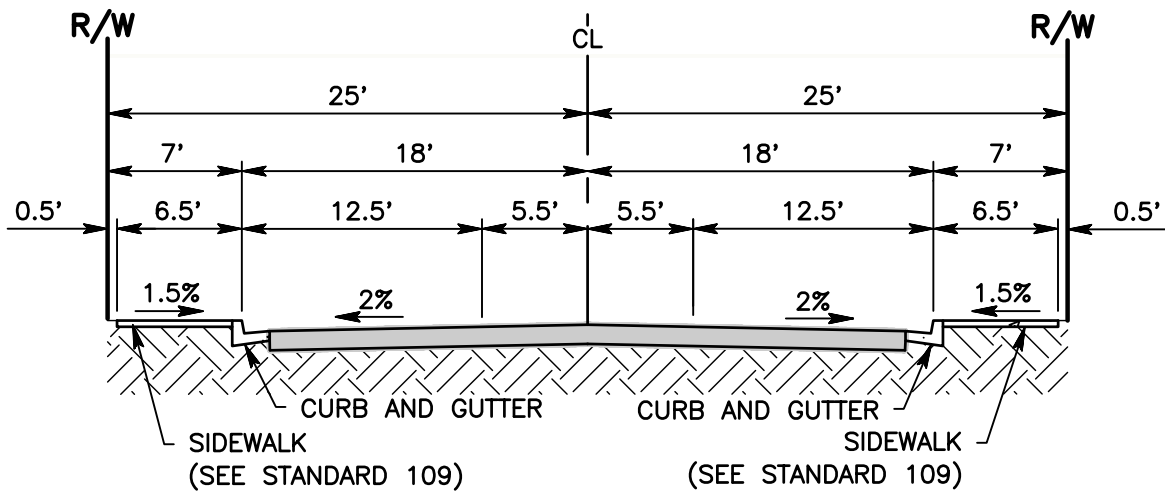

TYPICAL SECTION

NOTES:

1. STRUCTURAL SECTION OF ROADWAY SHALL BE DETERMINED FROM SOIL TESTS AND SO ON INDICATED CONSTRUCTION PLANS.
2. CONSTRUCTION OUTSIDE RIGHT OF WAY LINE SHALL REQUIRE SLOPE EASEMENTS.
3. 0.6% GRADE MIN. ON GUTTER OF BULB.
4. TILT SECTION SHALL CONFORM TO LOCAL STREET STA104.
5. X INDICATES POSITION OF SURVEY REFERENCE POINT (#10 ROUND HEAD BRASS SCREW MINIMUM LENGTH 1 1/4") SET FLUSH WITH TOP OF CURB DURING CONSTRUCTION.



SAN BERNARDINO COUNTY DEPARTMENT OF PUBLIC WORKS

OFFSET CUL-DE-SAC

BRENDON P. BIGGS, PE
DIRECTOR OF PUBLIC
WORKS/ROAD
COMMISSIONER

120A