

FRAME AND COVER – SECTION

DIA = DIAMETER
MIN = MINIMUM

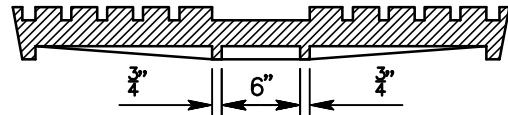

COVER – SECTION

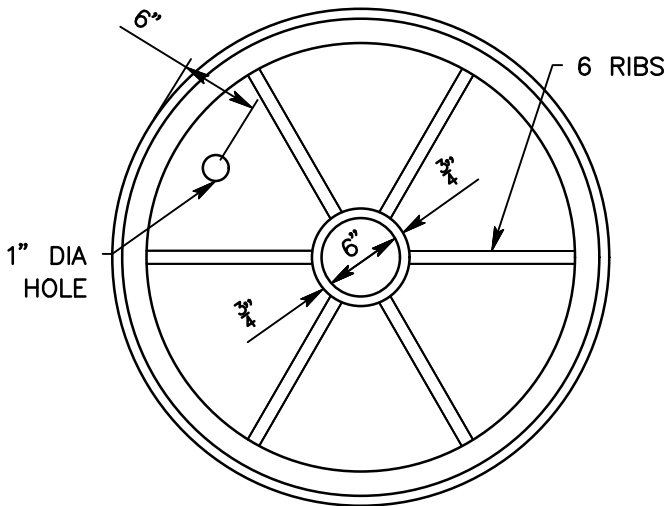

BOTTOM VIEW

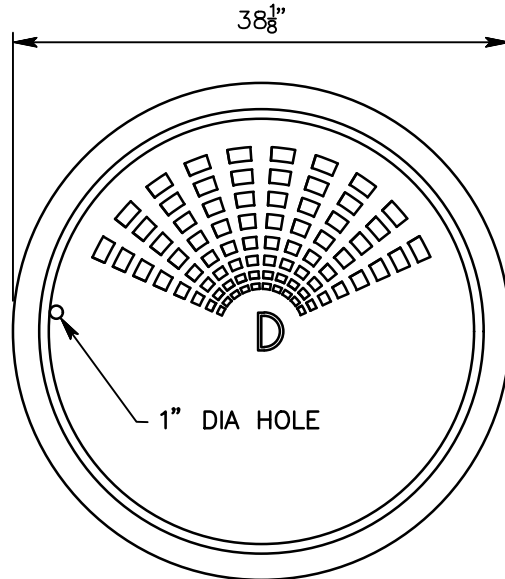

PLAN

NOTES:

1. SEATS OF FRAME AND COVER SHALL BE MACHINED TO PREVENT NOISE.
2. TOTAL WEIGHT OF FRAME AND COVERS – 580 LBS MINIMUM.
3. MATERIAL SHALL BE CAST IRON (BITUMINOUS COATED).
4. SURFACE OF LETTERS SHALL BE FLUSH WITH FINISHED SURFACE OF COVER.



SAN BERNARDINO COUNTY DEPARTMENT OF PUBLIC WORKS

36" MANHOLE FRAME AND COVER

BRENDON P. BIGGS, PE
DIRECTOR OF PUBLIC
WORKS/ROAD
COMMISSIONER

205