

**TYPICAL SECTION
WITH RAISED MEDIAN**

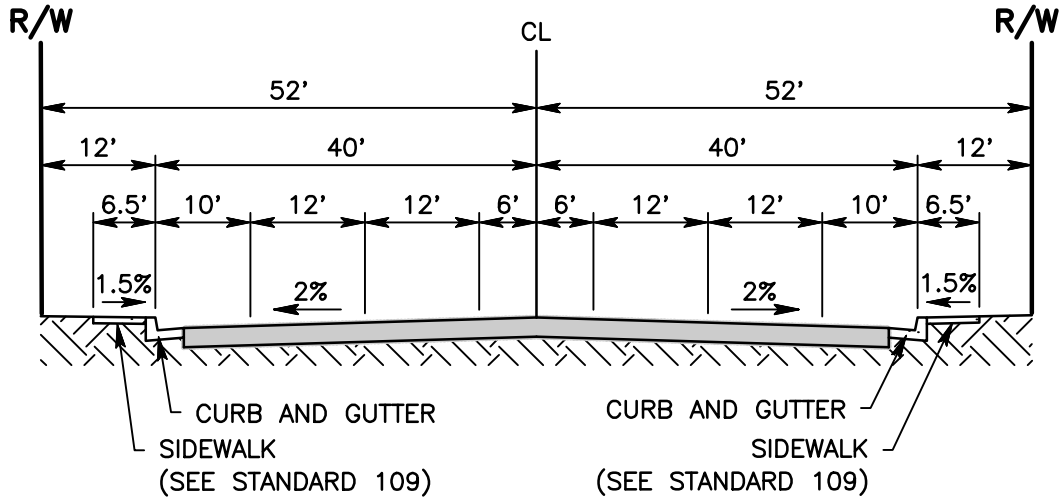

**TYPICAL SECTION
WITH CONTINUOUS LEFT TURN LANE**

NOTES:

1. STRUCTURAL SECTION OF ROADWAY SHALL BE DETERMINED FROM SOILS TEST AND SO INDICATED ON CONSTRUCTION PLANS.
2. DRAINAGE FACILITIES SHALL BE PROVIDED TO DEWATER RAISED MEDIAN AREAS.
3. TEN FEET (10') SHOULDER AREAS MAY BE DESIGNATED AS A BIKE LANE AND EMERGENCY PARKING ONLY.
4. IRRIGATION SYSTEM IN MEDIAN AREA SHALL BE DRIP OR BUBBLE SYSTEM.
5. CROSS SLOPE FOR SIDEWALK SHALL NOT EXCEED 1.5% OR MEET ADA COMPLIANCE.



SAN BERNARDINO COUNTY DEPARTMENT OF PUBLIC WORKS

**MAJOR HIGHWAY
CHINO HILLS SPECIFIC PLAN AREA**

BRENDON P. BIGGS, PE
DIRECTOR OF PUBLIC
WORKS/ROAD
COMMISSIONER

102A