

DIA = DIAMETER
 FHWA = FEDERAL HIGHWAY
 ADMINISTRATION

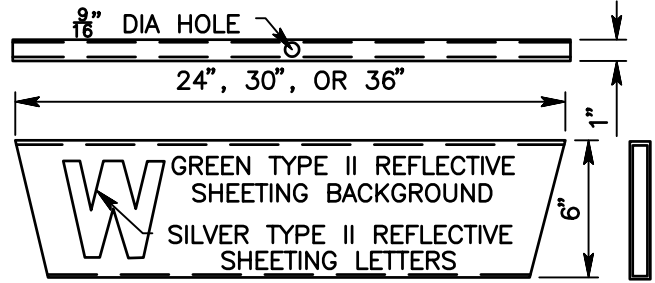
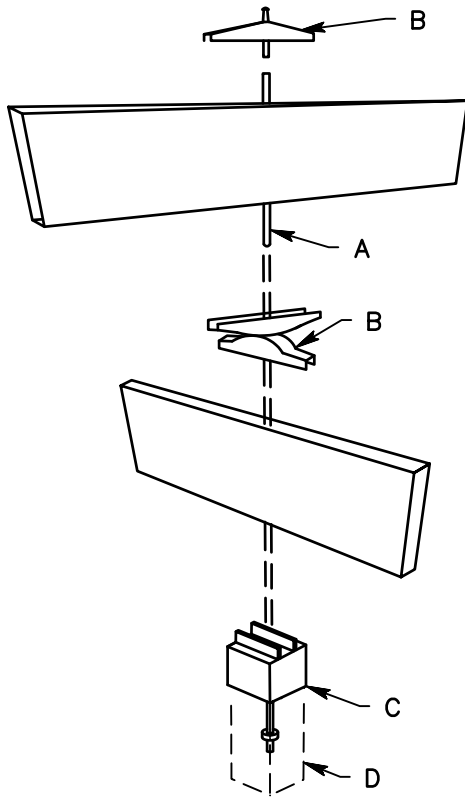

ASSEMBLY

- A $\frac{5}{8}$ " x 15" CADMIUM PLATED CARRIAGE BOLT.
- B ORNAMENTAL TOP SHALL BE 14 GAGE ANODIZED ALUMINUM. CENTER CROSS SADDLE SHALL BE ONE PIECE CAST ANODIZED ALUMINUM.
- C ONE PIECE 2" CAST ANODIZED ALUMINUM POST CAP WITH FOUR $\frac{3}{8}$ " STAINLESS STEEL ALLEN HEAD SET SCREWS.
- D 2" SQUARE STEEL POST 8'-12' LONG INSTALLED WITH A DRIVEN 2 $\frac{1}{2}$ " SQUARE STEEL BREAKAWAY BASE 3' LONG AS PER STANDARD 303B.

DESIGN: EACH FOUR-WAY UNTIL SHALL CONSIST OF TWO DOUBLE FACE SIGNS WITH STREET NAMES MOUNTED AT RIGHT ANGLES WITH CENTER ROD ASSEMBLY.

BRACKET ASSEMBLY: THE POST CAP, ORNAMENT, AND CENTER ROD ASSEMBLY SHALL BE MADE TO MOUNT ON 2" SQUARE GALVANIZED POST. THE CENTER ROD SHALL BE A $\frac{5}{8}$ " CADMIUM PLATED CARRIAGE BOLT. HEAD OF BOLT SHALL FORM TOP OF ORNAMENT. BOLT SHALL EXTEND THROUGH SIGNS AND FASTEN WITH NUT INSIDE OF POST CAP. POST CAP SHALL BE DEEPLY GROOVED TO SECURELY HOLD SIGN FROM TWISTING AND SHALL BE SECURED TO THE PIPE WITH THREE $\frac{3}{8}$ " STAINLESS STEEL ALLEN HEAD SET SCREWS.

MATERIAL: SIGN SHALL BE GREEN ANODIZED ALUMINUM EXTRUSION OF 6063T - 4 ALLOY MATERIAL. ALL ANODIZING SHALL CONFORM WITH ALUMILITE SPECIFICATIONS #215 - R1.

FINISH: SIGN FACES SHALL BE FHWA TYPE II REFLECTIVE SHEETING. THE TRANSPARENT SCREEN PROCESS COLOR SHALL BE AS RECOMMENDED BY THE REFLECTIVE SHEETING MANUFACTURER. APPLICATION OF THE REFLECTIVE SHEETING TO THE SIGN SHALL BE BY METHODS AS APPROVED BY THE REFLECTIVE SHEETING MANUFACTURER.

LETTERING: STREET NAMES SHALL BE 4" HIGH. EACH NAME SHALL BE INDIVIDUALLY LAID OUT TO FIT EITHER THE 24" OR 30" SPACE. THE LETTERS SHALL BE OF THE ROUNDED TYPE STYLE CONFORMING WITH THE STANDARD ALPHABET FOR HIGHWAY SIGNS DESIGNED BY THE U.S. PUBLIC ROADS ADMINISTRATION. LETTERS SHALL BE FHWA TYPE II REFLECTIVE SHEETING.



SAN BERNARDINO COUNTY DEPARTMENT OF PUBLIC WORKS

STREET MARKER

BRENDON P. BIGGS, PE
 DIRECTOR OF PUBLIC
 WORKS/ROAD
 COMMISSIONER

303